

SPECIFICATIONS FOR LCD MODULE

CUSTOMER	
MODEL	SCT035001-V01
CUSTOMER APPROVED	

APPROVED BY	CHECKED BY	ORGANIZED BY
	Lr.Yin	Wf.Luo

ADD : 6F. B block of 10 Building Huafeng Technology Park. Fengtang Road

Fuyong town Baoan district Shenzhen Guangdong

TEL : 0755-81452160

FAX : 0755-81452166

Contents

1. General Description	3
2. Physical Features	3
3. Mechanical Specification	3
4. Outline Dimension	4
5. Absolute Maximum Ratings.....	5
6. Electrical Characteristics	5
7. Module Function Description	6
8. Backlight Characteristics.....	10
9. Electro-Optical Characteristics.....	11
10. Reliability	13
11. Inspection Standards	14
12. Precautions For Using LCD Modules.....	20
13. Records Of Version.....	22

1. General Description

SCT035 is a transmissive type a-Si TFT-LCD (amorphous silicon thin film transistor liquid crystal display) module, which is composed of a TFT-LCD panel, a driver circuit and a backlight unit. The panel size is 3.5 inch and the resolution is 320*240, the panel can display up to 16M colors. The LCM can be easily accessed by micro-controller via RGB interface.

2. Physical Features

Display Mode	TFT-LCD Module
	Active matrix TFT, Transmissive type
Display Format	Graphic 320×RGB×240 Dot-matrix
Input Data	24 bit RGB with Serial Interface
Viewing Direction	12 O'clock
Drive	HX8238-D

3. Mechanical Specification

Item	Contents	Unit
Module size (W×H×T)	76.90 × 63.90 × 3.20	mm
Number of dots	320(RGB) × 240	---
Active area (W×H)	70.08 × 52.56	mm

4.Outline

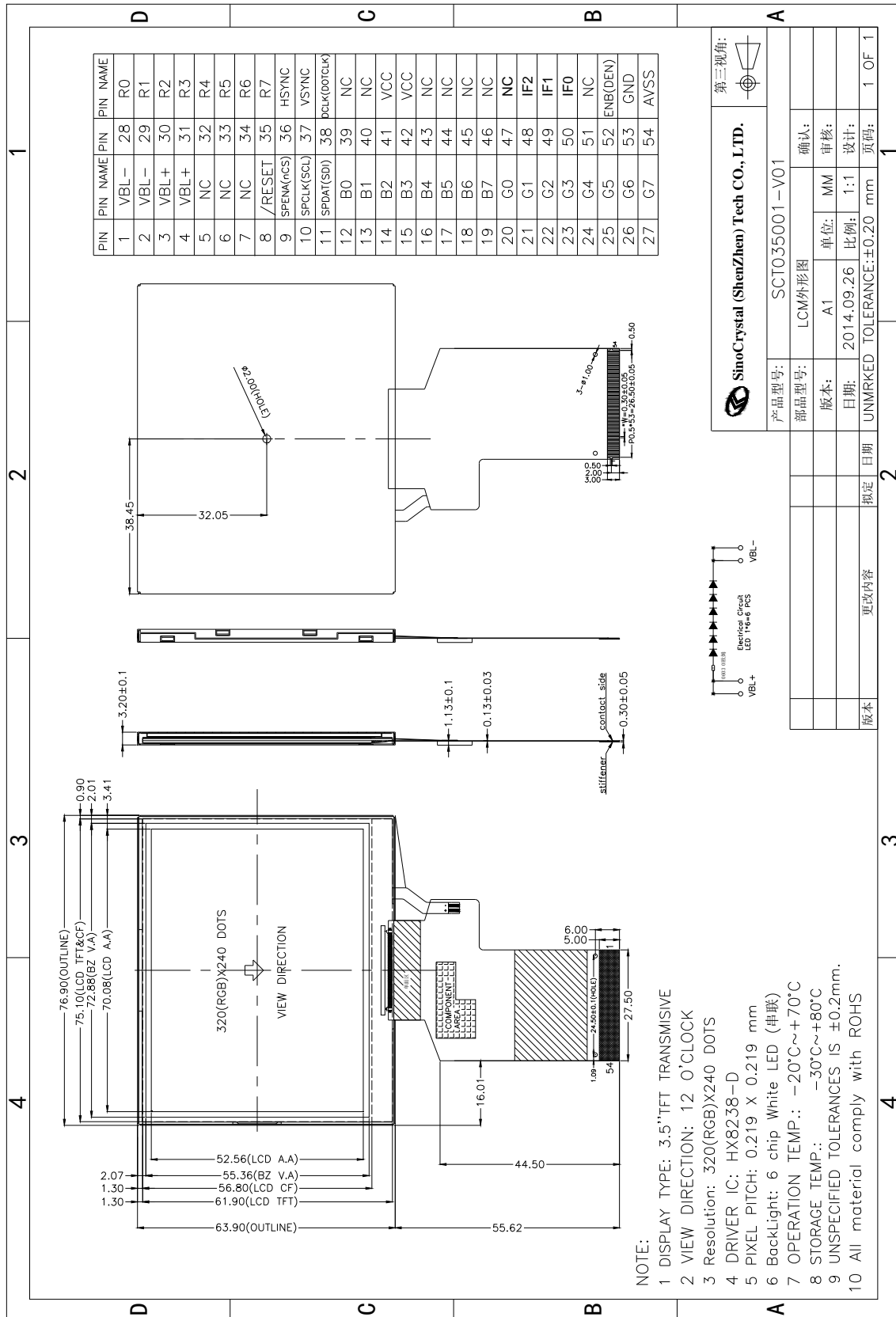

5. Absolute Maximum Ratings

Item	Symbol	Min	Max	Unit	Remark
Power Voltage	VCC	-0.3	4	V	Note1、 Note2
Input Voltage	VIN	-0.3	VCC+0.3	V	
Operating temperature	TOPR	-20	70	°C	
Storage temperature	TSTR	-30	80	°C	
Humidity	---	---	90	%RH	---

Remark:

Note 1) The HX8238-D may be permanently damaged if it is used under the condition exceeding the above absolute maximum values. It is also recommended to use the HX8238-D within the limit of its electric characteristics during normal operation. Exceeding the conditions may lead to malfunction of HX8238-D and affect its credibility.

Note 2) The voltage from VSS.

6. Electrical Characteristics

Item		Symbol	Rating			Unit	Remark
			Min	Typ	Max		
Power Voltage	Logic	VCC	2.5	3.3	3.6	V	Note1
Input Voltage	L level	VIL	-0.3	----	0.2*VCC	V	VCC=2.5 ~ 3.6V
	H level	VIH	0.8* VCC	---	---	V	
LCD Drive Power current		ILCD	---	TBD	---	mA	---

Remark:

Note1:Vcom must be adjusted to optimize display quality: Cross-talk, Contrast Ratio and etc.

7. Module Function Description

7-1. Block Diagram Of LCM

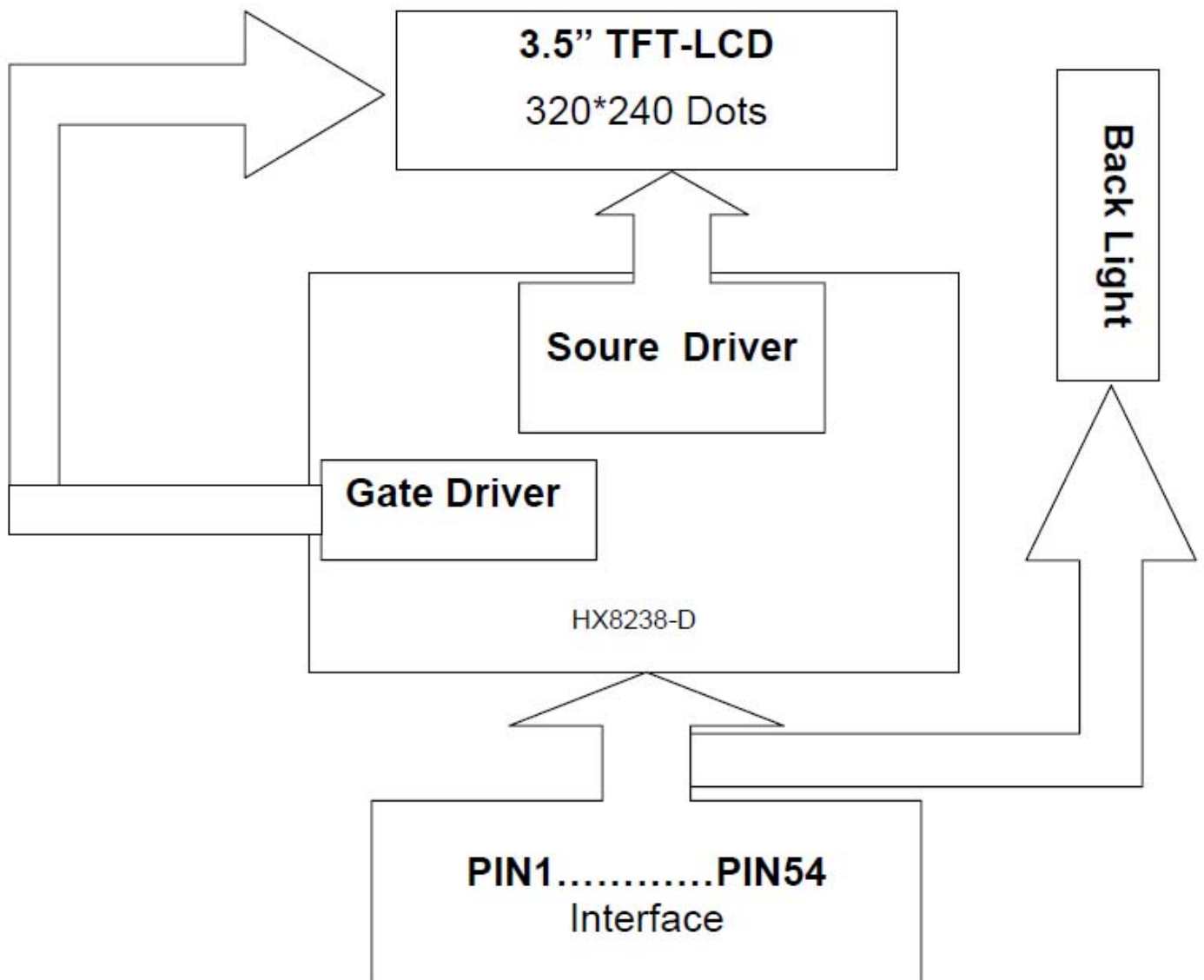

7-2. Pin Description

Pin	Symbol	I/O	Function	Remark
1	VBL-	I	Backlight LED Ground	
2	VBL-	I	Backlight LED Ground	
3	VBL+	I	Backlight LED Power	
4	VBL+	I	Backlight LED Power	
5	Y1	I	Top electrode ,	
6	X1	I	Right electrode	
7	NC		Not Use	
8	/RESET	-	Hardware Reset	
9	SPENA	I	SPI Interface Data Enable Signal	Note 3
10	SPCLK	I	SPI Interface Data Clock	Note 3
11	SPDAT	I	SPI Interface Data	Note 3
12	B0	I	Blue Data Bit 0	
13	B1	I	Blue Data Bit 1	
14	B2	I	Blue Data Bit 2	
15	B3	I	Blue Data Bit 3	
16	B4	I	Blue Data Bit 4	
17	B5	I	Blue Data Bit 5	
18	B6	I	Blue Data Bit 6	
19	B7	I	Blue Data Bit 7	
20	G0	I	Green Data Bit0	
21	G1	I	Green Data Bit1	
22	G2	I	Green Data Bit2	
23	G3	I	Green Data Bit3	
24	G4	I	Green Data Bit4	
25	G5	I	Green Data Bit5	
26	G6	I	Green Data Bit6	
27	G7	I	Green Data Bit7	
28	R0	I	Red Data Bit0 /DX0	Note 4
29	R1	I	Red Data Bit1 /DX1	Note 4
30	R2	I	Red Data Bit2 /DX2	Note 4
31	R3	I	Red Data Bit3 /DX3	Note 4
32	R4	I	Red Data Bit4 /DX4	Note 4
33	R5	I	Red Data Bit5 /DX5	Note 4
34	R6	I	Red Data Bit6 /DX6	Note 4

35	R7	I	Red Data Bit7 /DX7	Note 4
36	HSYNC	I	Horizontal Sync Input	
37	VSYNC	I	Vertical Sync Input	
38	DCLK	I	Dot Data Clock	
39	NC		Not Use	
40	NC		Not Use	
41	Vcc	I	Digital Power	
42	Vcc	I	Digital Power	
43	Y2	I	Bottom electrode	
44	X2	I	Left electrode	
45	NC	-	Internal test use	
46	NC	-	Not Use	
47	NC	-	Internal test use	
48	IF2	I	Control the input data format /floating	Note 1
49	IF1	I	Control the input data format	Note 1,5
50	IF0	I	Control the input data format	Note 1,5
51	NC		Not Use	
52	DE	I	Data Enable Input	Note 2
53	GND	I	Ground	
54	GND	I	Ground	

Note:

1. The mode control (IF2) not use ,it can't control CCIR601 interface , If not use CCIR601 ,it can floating.
2. For digital RGB input data format, both SYNC mode and DE+SYNC mode are supported. If DE signal is fixed low, SYNC mode is used. Otherwise, DE+SYNC mode is used.Suggest used SYNC mode!!
3. usually pull high.
4. IF select serial RGB or CCIR601/656 input mode is selected,only DX0-DX7 used,and the other short to GND. Only selected serial RGB 、CCIR601/656 interface,DX BUS will enable,Digital input mode DX0 is LSB and DX7 is MSB.
5. Control the input data format

IF2-0: Define the input interface mode.

IF2	IF1	IF0	Format	Operating Frequency
0	0	0	Parallel-RGB data format (only support stripe type color filter)	6.5MHz
0	0	1	Serial-RGB data format	19.5MHz
0	1	0	CCIR 656 data format (640RGB)	24.54MHz
0	1	1	CCIR 656 data format (720RGB)	27MHz
1	0	0	YUV mode A data format (Cr-Y-Cb-Y)	24.54MHz
1	0	1	YUV mode A data format (Cr-Y-Cb-Y)	27MHz
1	1	0	YUV mode B data format (Cb-Y-Cr-Y)	27MHz
1	1	1	YUV mode B data format (Cb-Y-Cr-Y)	24.54MHz

Input format	DOTCLK Freq (MHz)	Display Data	Active Area (DOTCLK)
YUV mode	24.54	640	1280
	27	720	1440

Mode	D[23:16]	D[15:8]	D[7:0]	IHS	IVS	DEN
ITU-R BT 656	D[23:16]	GND	GND	NC	NC	NC
ITU-R BT 601	D[23:16]	GND	GND	IHS	IVS	NC
8 bit RGB	D[23:16]	GND	GND	IHS	IVS	NC for HV Mode DEN for DEN Mode
24 bit RGB	R[7:0]	G[7:0]	B[7:0]	IHS	IVS	NC for HV Mode DEN for DEN Mode

7-3. Timing Characteristics

7.3.1 3Wire SPI Timing Characteristics

First Transmission (Register)

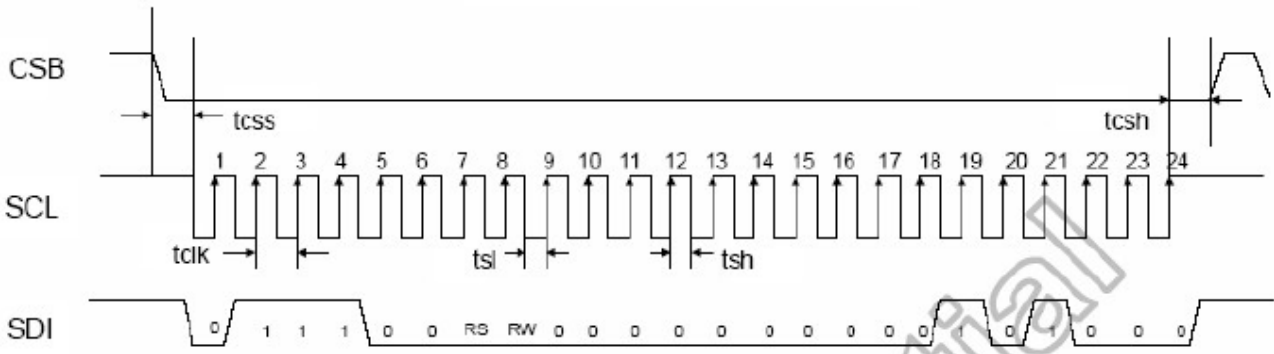

Second Transmission (Data)

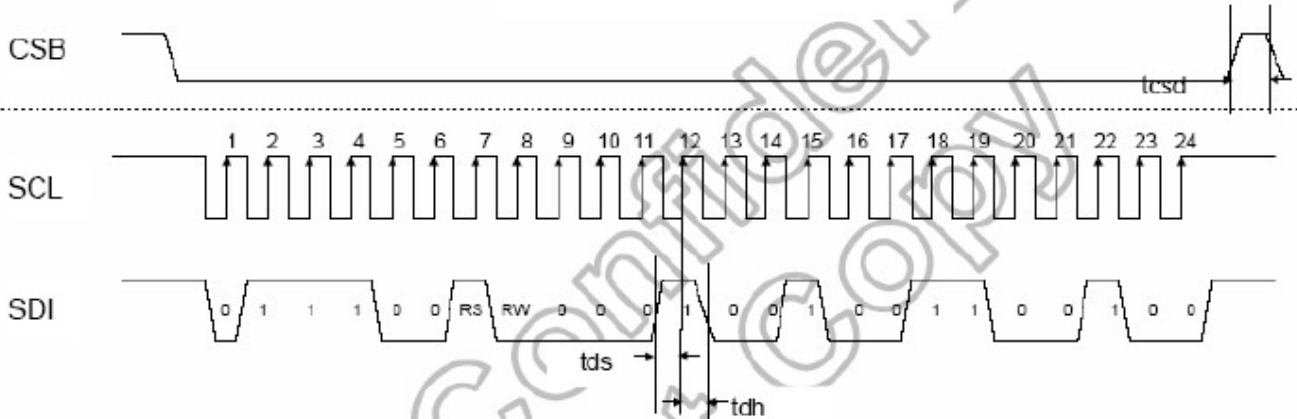

Note: The example writes "0x1264h" to register R28h. SPID connected to VSS.

Characteristics	Symbol	Spec.			Unit
		Min.	Typ.	Max.	
Serial Clock Frequency	fclk	-	-	20	MHz
Serial Clock Cycle Time	tclk	50	-	-	ns
Clock Low Width	tsl	25	-	-	ns
Clock High Width	tsh	25	-	-	ns
Clock Rising Time	trs	-	-	30	ns
Clock Falling Time	tfl	-	-	30	ns
Chip Select Hold Time	tcss	10	-	-	ns
Chip Select High Delay Time	tcsd	20	-	-	ns
Data Setup Time	tds	5	-	-	ns
Data Hold Time	tdh	10	-	-	ns

7.3.2 RGB Interface Timing Characteristics

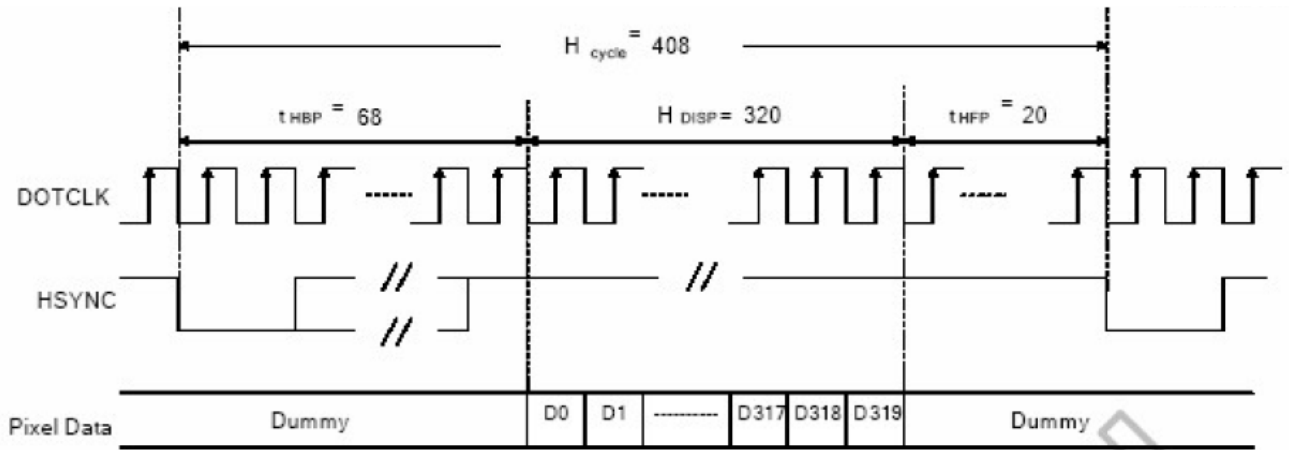

(a) Horizontal Data Transaction Timing

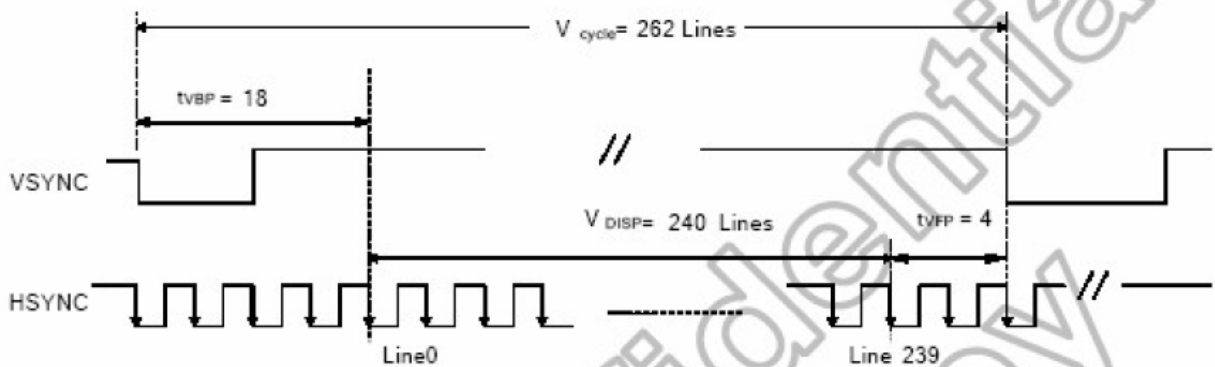

(b) Vertical Data Transaction Timing

Figure 12. 2: Data transaction timing in parallel RGB (24-bit) interface (SYNC mode)

7.3.3 Input timing specifications

Characteristics	Symbol	Min.		Typ.		Max.		Unit
		24-bit	8-bit	24-bit	8-bit	24-bit	8-bit	
DOTCLK Frequency	f _{DOTCLK}	-	-	6.5	19.5	10	30	MHz
DOTCLK Period	t _{DOTCLK}	100	33.3	154	51.3	-	-	ns
Horizontal Frequency (Line)	f _H	-	-	14.9	-	22.35	-	KHz
Vertical Frequency (Refresh)	f _V	-	-	60	-	90	-	Hz
Horizontal Back Porch	t _{HBP}	-	-	68	204	-	-	t _{DOTCLK}
Horizontal Front Porch	t _{HFP}	-	-	20	60	-	-	t _{DOTCLK}
Horizontal Data Start Point	t _{HBP}	-	-	68	204	-	-	t _{DOTCLK}
Horizontal Blanking Period	t _{HBP} + t _{HFP}	52	146	88	264	180	960	t _{DOTCLK}
Horizontal Display Area	H _{DISP}	-	-	320	960	-	-	t _{DOTCLK}
Horizontal Cycle	H _{cycle}	372	1106	408	1224	500	1920	t _{DOTCLK}
Vertical Back Porch	t _{VBP}	-	-	18	-	-	-	Lines
Vertical Front Porch	t _{VFP}	-	-	4	-	-	-	Lines
Vertical Data Start Point	t _{VBP}	-	-	18	-	-	-	Lines
Vertical Blanking Period	NTSC	10		22		47		Lines
	PAL	20		33		120		
	PAL	12		25		112		
Vertical Display Area	NTSC	-		240		-		Lines
	PAL	-		280(PALM=0)		-		
	PAL	-		288(PALM=1)		-		
Vertical Cycle	NTSC	250		262		287		Lines
	PAL	300		313		400		

8. Backlight Characteristics

Item	Symbol	Min	Typ	Max	Unit	Remark
Forward voltage	V_{BL}	18	19.2	20	V	-
Current	I_{BL}	-	20	-	mA/chip	-
ICE	X	0.26	-	0.32	-	-
	Y	0.26	-	0.32	-	-
Brightness		3000		-	cd/m ²	★1
Uniformity	-	80	-	-	%	★2

★1 Test condition is :

- (a) Center point on active area
- (b) Best Contrast

★2 Uniform measure condition :

- (1) Measure 9 point. Measure location is show below :
- (2) Uniform = (Min. brightness / Max. brightness) × 100%
- (3) Best Contrast.

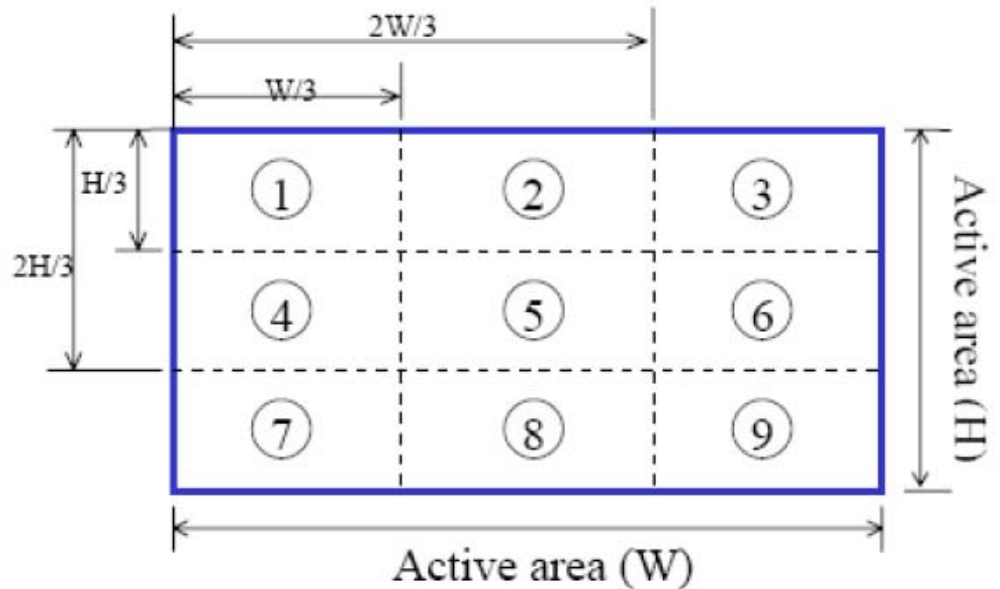

9. Electro-Optical Characteristics

(Ta = 25 °C, If = 40 mA)

Item		Symbol	Condition	Min	Typ.	Max	Unit	Remark			
Viewing Angle	Horizontal	ΘL	Center CR≥10	50	60	---	Deg.	Note 3 ,2			
		ΘR		50	60	---					
	Vertical	ΘU		50	60	---					
		ΘD		30	50	---					
Contrast Ratio		CR	At optimized View Angle	250	350	---	---	Note 1,4			
Luminance		Lv	Θ=0°	350	400	---	cd/mm ²	Note 1,5			
Uniformity		LU		80	---	---	%	Note1,6			
Response Time		Tr	Θ=0°	---	10	20	ms	Note 7			
		Tf		---	15	30	ms				
Color Chromaticity	White	X	Θ=0°	0.275	0.305	0.335	---	---			
		Y		0.304	0.334	0.364					
	Red	X		0.578	0.608	0.638					
		Y		0.286	0.316	0.346					
	Green	X		0.275	0.305	0.365					
		Y		0.526	0.556	0.586					
	Blue	X		0.105	0.135	0.165					
		Y		0.107	0.137	0.167					
	NTSC				---	53%			---		

Note 1: Measuring equipments: DMS-501, PR-705.

Measuring condition:

- After stabilizing and leaving the panel alone at a given temperature for 30 min, the measurement should be executed,
- Measuring surroundings: a stable, windless and dark room,
- Measuring temperature: Ta=25°C,
- 30 min after lighting the back-light.

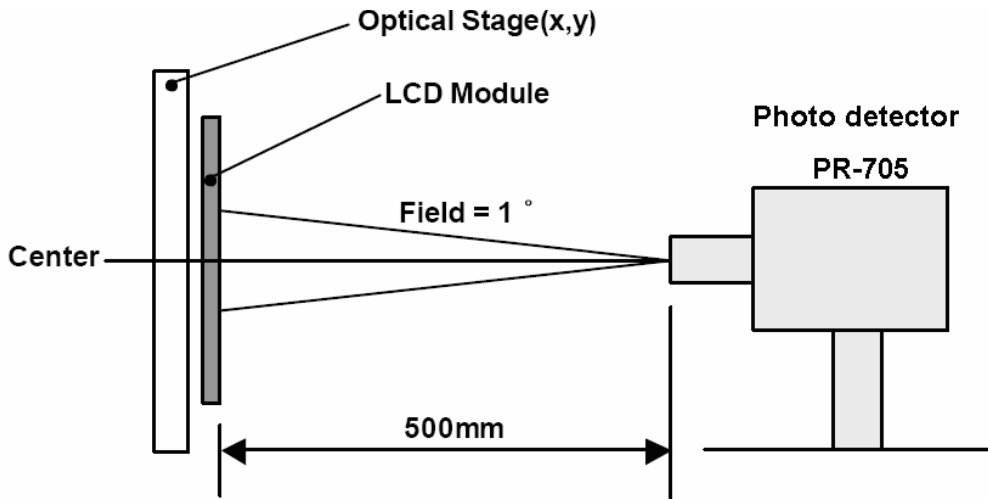

Note 2: The definition of viewing angle:

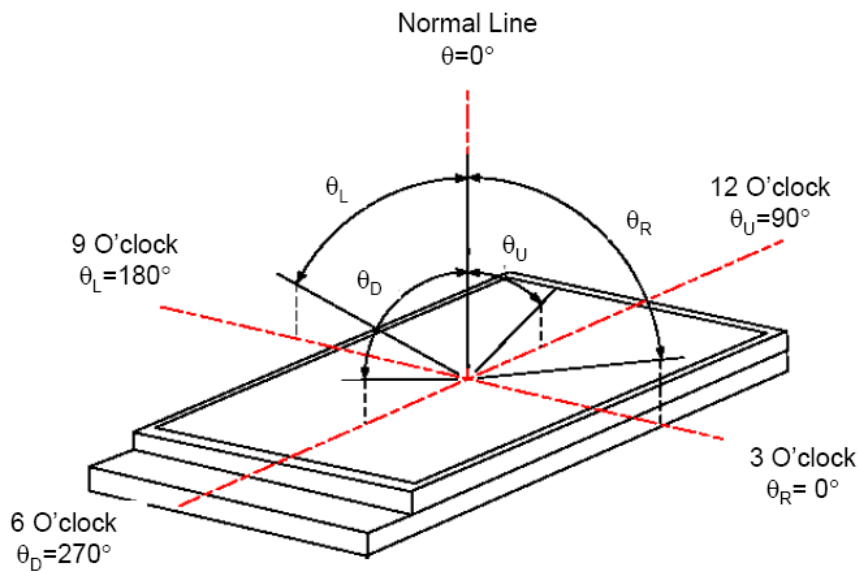

Note 3: The definition of viewing direction:

The definition of viewing direction is for good image quality, which is 12 O'clock. View Direction for Largest Contrast Ratio is 6 O'clock.

Note 4: The contrast ratio (CR) is defined as follows:

$$CR = \frac{\text{Luminance with all pixels white}}{\text{Luminance with all pixels black}}$$

Measure the luminance at the center of the screen.

Note 5: Definition luminance of White: measure the luminance of White at the center of the screen.

Note 6: The definition of luminance uniformity:

The luminance uniformity is calculated by using following formula.

$$\text{Luminance uniformity (Lu)} = \frac{\text{Minimum luminance from 1 to 9}}{\text{Maximum luminance from 1 to 9}}$$

The luminance is measured at near the 9 points shown below.

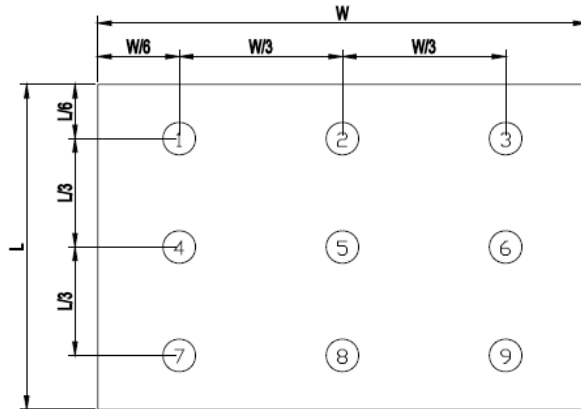

Note7: The definition of response time:

The output signals of photo detector are measured when the input signals are changed from “black” to “white” (falling time) and from “white” to “black” (rising time), respectively. The response time is defined as the time interval between the 10% and 90% of amplitudes. Refer to figure as below:

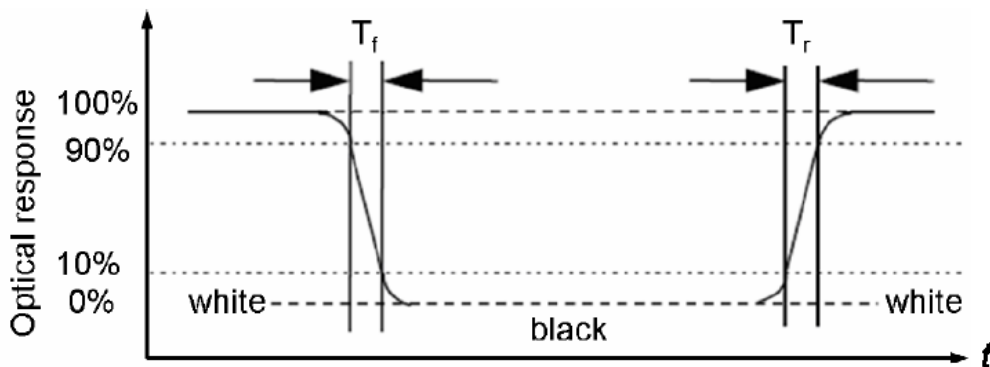

10. Reliability

10. 1. MTBF

The LCD module shall be designed to meet a minimum MTBF value of 50000 hours with normal. (25°C in the room without sunlight)

10. 2. Test condition

ITEM	CONDITIONS	CRITERION
OPERATING TEMPERATURE	HIGH TEMPERTURE +70°C 48HRS	NO DEFECT IN DISPLAYING AND OPERATIONAL FUNCTION
	LOW TEMPERTURE -20°C 48HRS	
STORAGE TEMPERATURE	HIGH TEMPERTURE +80°C 48HRS	NO DEFECT IN DISPLAYING AND OPERATIONAL FUNCTION
	LOW TEMPERTURE -30°C 48HRS	
HUMIDITY	60°C 90%RH 48HRS	NO DEFECT IN DISPLAYING AND OPERATIONAL FUNCTION

11. Inspection Standards

1. AQL(Acceptable Quality Level)

AQL of major and minor defect

	MAJOR DEFECT	MINOR DEFECT	MAJOR+MINOR
APPEARANCE	0.40%	1.0%	1.0%
ELECTRIC-OPTICAL	0.15%	0.15%	0.15%

2. Basic conditions for inspection

The LCM face to us, in normal environment, the lux is 1000±200.(Darkroom's lux:100±50),

About an angle of incidence 30, a distance of 30cm with normal eye,with an angle of 45 degree to check the products without uncovering the film!

(As shown below)

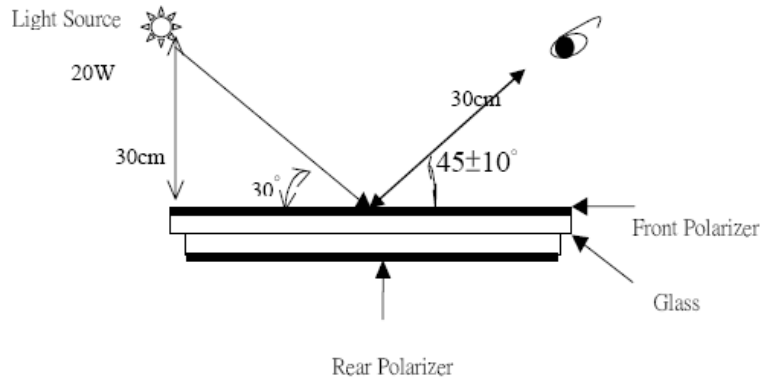

3. Inspection item and criteria

3.1 Visual inspection criterion in immobility

3.1.1 Glass defect

No	Defect item	Criteria	Remark
1	Dimension Unconformity (Major defect)	By Engineering Drawing	

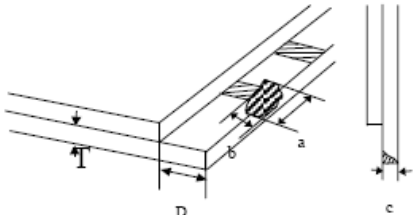
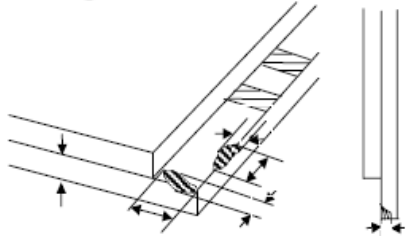
No	Defect item	Criteria	Remark
2	Cracks (Major defect)	1.Linear cracks on panel 【Reject】 2. Nonlinear crack contrast by limited sample	
3	Glass extrude the conductive area (minor defect)	a: disregards and no influence assemblage 1) $b \leq 1/3$ Pin width(non bonding area) 【Accept】 2) bonding area $\leq 0.5\text{mm}$ 【Accept】	a:Length, b:Width
4	Pin-side , conductive area damaged (minor defect)	(a c : disregards) $b \leq 1/3$ of effective length for bonding electrode 【Accept】	a: Length , b : Width , c : Thickness 
5	Pin-side , non-conductive area damaged (minor defect)	1) Damage area don't touch the ITO (Including contraposition mark,except scribing mark) 【Accept】 2) $c < T$ $b \leq BM$ 1/3 of width 【Accept】 3) $c = T$ b not touch the seal glue 【Accept】 4) a disregards	a: Length , b : Width , c : Thickness 

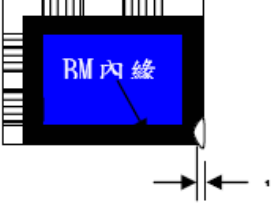
No	Defect item	Criteria	Remark
6	Non-pin-side damage (minor defect)	c<T 1) b exceeds 1/3 BM	c : Thickness b: width of damage 
		c=T b not touch the seal glue	
		【Reject】	
		【Reject】	

3.1.2 LCD appearance defect (View area)

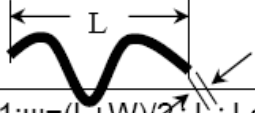
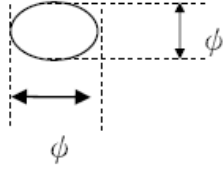
No	Defect item	Criteria	Remark
1	Fiber 、 glass cratch 、 polarizer scratch/folded (minor defect)	Specification	note1: L : Length , W : Width note2: disregard if out of AA 
		Allowable	
		$0.05\text{mm} < W \leq 0.1\text{mm};$ $L \leq 3.0\text{mm}$	1
		$W > 0.1\text{mm}; L > 3.0\text{mm}$	0
2	Polarizer bubble 、 concave and convex (minor defect)	$\psi \leq 0.2\text{mm}$	disregard
		$0.2\text{mm} < \psi \leq 0.3\text{mm}$	2
		$0.3\text{mm} < \psi \leq 0.5\text{mm}$	1
		$0.5\text{mm} < \psi$	0
3	Black dots 、 dirty dots 、 impurities 、 eyewinker (Major defect)	$\psi \leq 0.15\text{mm}$	disregard
		$0.15\text{mm} < \psi \leq 0.25\text{mm}$	2
		$0.25\text{mm} < \psi \leq 0.3\text{mm}$	1
		$0.3\text{mm} < \psi$	0
			note 1: $\psi = (L+W)/2$; L : Length , W : Width note2: disregard if out of AA 
4	Polarizer prick (Major defect)	$\psi \leq 0.1\text{mm}$	disregard
		$0.1\text{mm} < \psi \leq 0.25\text{mm}$	3
		$\psi > 0.25\text{mm}$	0
			note1: $\psi = (L+W)/2$; L= Length , W=Width note2: the distance between two dots > 5mm

3.1.3 .FPC

No	Defect item	Criteria		Remark
1	Copper screen peel (Major defect)	Copper screen peel 【 Reject】		
2	No release tape or peel (Major defect)	No release tape or peel 【 Reject】		
3	Dirty dot and impurity of FPC for customer using side (minor defect)	Specification	Allowable	note1: Cannot have stride ITO impurities
		$\psi \leq 0.25\text{mm}$	2	
		$\psi > 0.25$	0	

3.1.4 Black tape & Mara tape

1	FPC or H/S black tape shift (minor defect)	1.shift spec: 1)glue to the polarize 【 Reject】 2) IC bare 【 Reject】 2. left-and-right spec: 1) exceed of FPC edge or H-S edge 【 Reject】 2)IC bare 【 Reject】	
2	No black tape (Major defect)	No black tape 【 Reject】	
3	Tape position mistake (minor defect)	Not by engineering drawing 【 Reject】	
4	Mara tape defect (minor defect)	Peel before pulling the protecting film. 【 Reject】	

3.1.5 Silicon and Tuffy glue

No	Defect item	Criteria	Remark
1	Quantity of silicon (minor defect)	Uncover the ITO and circuit area. 【 Reject】	note: compared by engineering drawing.

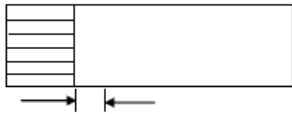
No	Defect item	Criteria	Remark
2	Tuffy glue (minor defect)	1. Uncover the reveal copper area 【 Reject 】 2. Cover layer 0.3mm(Min) ~ 3.0mm(Max) 【 accept 】	note:if customer has special requirement , refer to the technical document. 
3	Depth of glue covering (minor defect)	Depth of glue covering ovetop front Polarizer 【 Reject 】	Except of the special requirement °

3.2 Electrical criteria

No	Defect item	Criteria	Remark
1	No display (Major defect)	No display 【 Reject 】	
2	Missing line (Major defect)	Missing line 【 Reject 】	
3	Seg-com light and dark (Major defect)	Seg-com light and dark 【 Reject 】	ND filter 2% test
4	No display in immobility (Major defect)	No display in immobility 【 Reject 】	
5	Flicker of Pattern (Major defect)	Flicker of Pattern 【 Reject 】	
6	Mura (Major defect)	ND filter 2% test	
7	Over current (Major defect)	Over current 【 Reject 】	
8	Voltage out of specification (Major defect)	Voltage out of specification 【 Reject 】	
9	Pattern blur ,error code (Major defect)	Pattern blur ,error code 【 Reject 】	
10	Dark light, Flicker (Major defect)	Dark light, Flicker 【 Reject 】	

12. Precautions For Using LCD Modules

Please pay attentions to the followings as using the LCD module.

12.1 Handling

- (a) Do not apply strong mechanical stress like drop, shock or any force to LCD module. It may cause improper operation, even damage.
- (b) Because the ITO film very fragile and easy to be damaged, do not hit, press or rub the display surface with hard materials.
- (c) Do not put heavy or hard material on the display surface, and do not stack LCD modules.
- (d) If the display surface is dirty, please wipe the surface softly with cotton swab or clean cloth.
- (e) Wipe off water droplets or oil immediately.
- (f) Protect the LCD module from ESD. It will damage the LSI and the electronic circuit.
- (g) Do not touch the output pins directly with bare hands.
- (h) Do not disassemble the LCD module.

12.2 Storage

- (a) Do not leave the LCD modules in high temperature, especially in high humidity for a long time.
- (b) Do not expose the LCD modules to sunlight directly.
- (c) The liquid crystal is deteriorated by ultraviolet. Do not leave it in strong ultraviolet ray for a long time.
- (d) Avoid condensation of water. It may cause improper operation.
- (e) Please stack only up to the number stated on carton box for storage and transportation. Excessive weight will cause deformation and damage of carton box.

12.3 Operation

- (a) When mounting or dismounting the LCD modules, turn the power off.
- (b) Protect the LCD modules from electric shock.
- (c) The Driver IC control algorithms stated above should always obeyed to avoid damaging the LSI and electronic circuit.
- (d) Be careful to avoid mixing up the polarity of power supply for backlight.

- (e) Absolute maximum rating specified above has to be always kept in any case. Exceeding it may cause non-recoverable damage of electronic components or, nevertheless, burning.
- (f) When a static image is displayed for a long time, remnant image is likely to occur.
- (g) Be sure to avoid bending the FPC to an acute shape, it might break FPC.

12.4 Others

- (a) If the liquid crystal leaks from the panel, it should be kept away from the eyes or mouth.
- (b) It is recommended to peel off the protection film on the ITO film slowly so that the electrostatic charge can be minimized.
- (c) It is recommended to peel off the protection film on the polarizer slowly so that the electrostatic charge can be minimized.

13. Records Of Version

Revision No	Revision Date	Description
Ver: A0	2013-05-24	First release